

StoneWall® ION

StoneWall ION's unmatched versatility and innovation allows it to be used in multiple different applications, both retaining and freestanding, with virtually no limits. Its unique, patented dual-face design gives both designers and installers the flexibility to build a retaining wall in a traditional, single size pattern, or the ability to alternate between two face sizes without the need to purchase different block. For freestanding walls, the same block can be used with alternating faces to create a sleek, modern double sided wall. Complete with matching left and right corners, the StoneWall ION system offers a solution for all requirements of a hardscape project.

Stretcher Unit

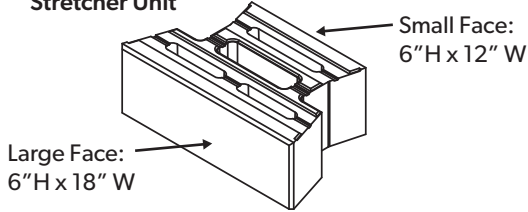

Corner Detail

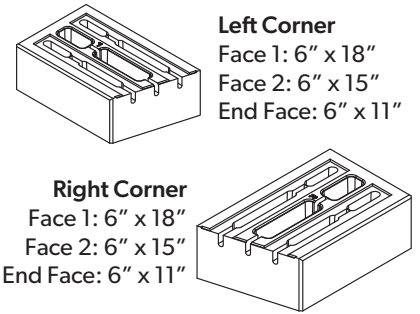

*Left and Right corners indicated by "L" and "R" stamped in to top of block during manufacturing.

Single Size Retaining (MSE) Application

Similar to most traditional single-face wall blocks, StoneWall ION can be installed in single-sided retaining (MSE) applications with the large face (6" H x 18" W) facing out on all block in a standard running bond pattern. The tapered sides also allow for convex curves where needed. If engineered properly, walls of any height can be built. For walls that contain corners, review the corner section on page 2 prior to building.

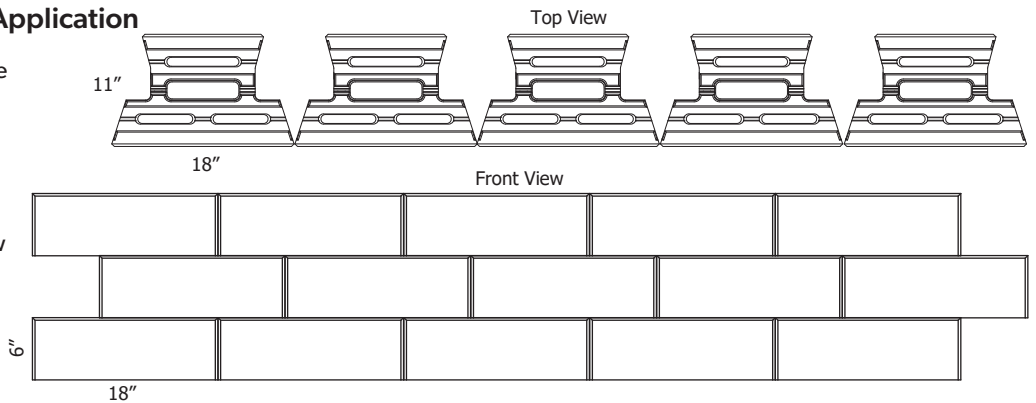

Dual Face Retaining (MSE) & Freestanding Application

StoneWall ION can also be installed in a dual-face, two size pattern. When installing, the block is placed alternating large (6" H x 18" W) and small (6" H x 12" W) faces. This will create a double sided wall that can be used in both freestanding and retaining applications. It is recommended that corners be used to start each course to ensure proper bond, alternating left and right corners row by row (shown below).

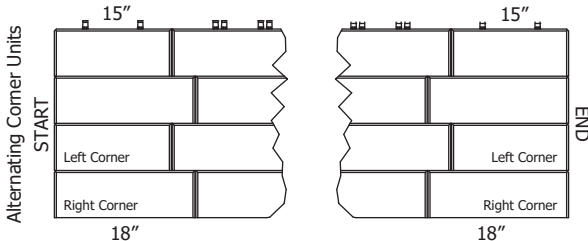
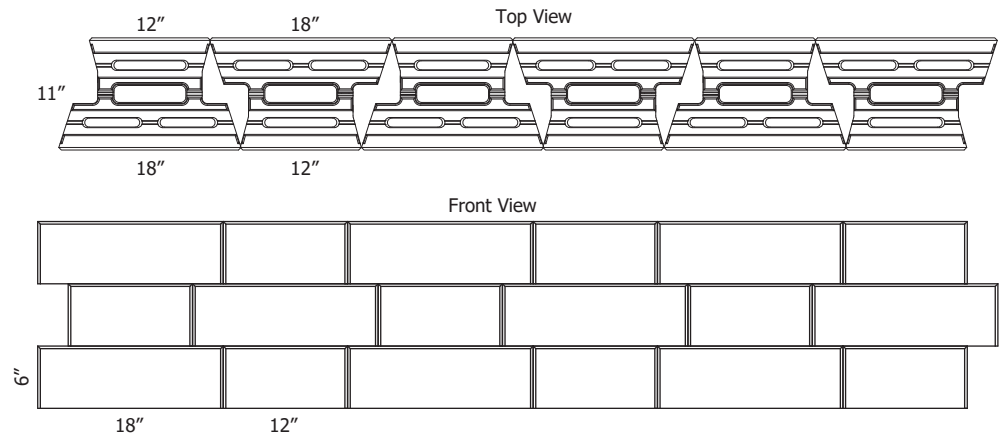

For walls that can not end with a full corner unit, a corner may be cut down to finish the end. To maintain a perfectly straight wall, a cut may be made where the longer side is exactly 3" wider than the shorter side, creating a matching taper (shown right).

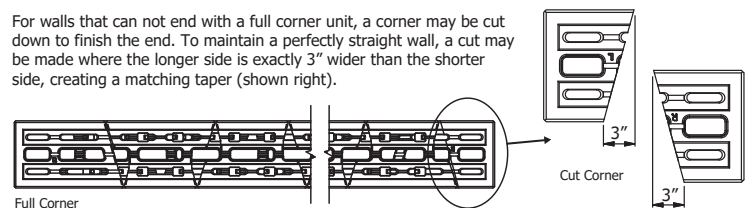

Continued >

StoneWall® ION (Continued)

Corners

StoneWall ION corners come in both left and right variations as indicated by a "L" or "R" stamped in to the top of the block during manufacturing. To create a corner in a wall, two corners (one left and one right) are used in each course, alternating their positions from row to row (shown below). Always build from the corner out after the initial course. Corners may also be used as end pieces as shown on page 1.

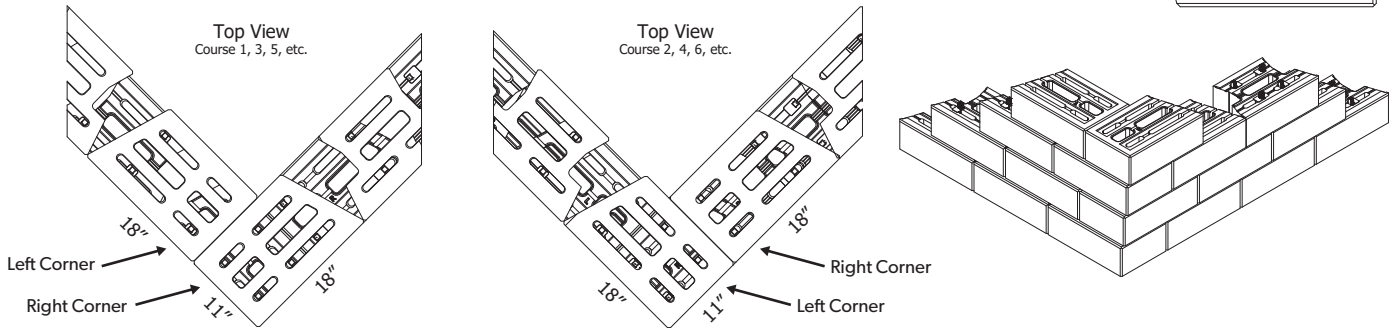

Pillars

Using corner units, matching StoneWall ION pillars can be built. To most efficiently build a pillar, it is recommended that they be built in 1' increments as corners are sold in pairs (one left and one right). Each layer contains four matching corners (four lefts or four rights) as shown below. Therefore, to build a complete layer, four corner sets are need, resulting in eight total blocks. Alternate between layers of lefts and rights as the height is increased.

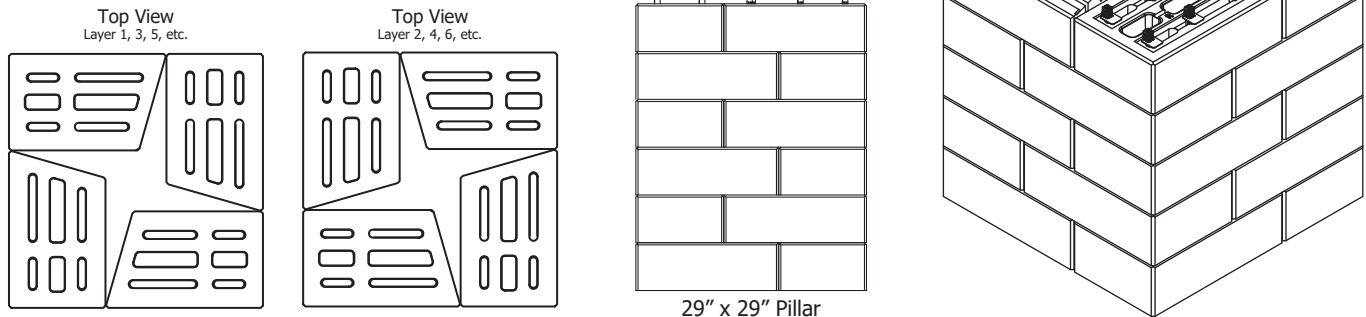

3-Way Alignment Plug

StoneWall ION uses our 3-way alignment plug for assistance in proper positioning when building walls. Its offset design allows for it to be placed in 3 different orientations to achieve different wall styles. Use one plug per block when building.

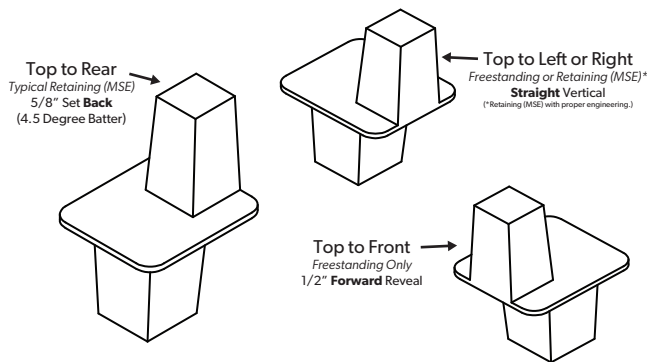

Special Considerations

Walls 39" and higher, terraced walls, sites with weak or wet soils, slopes and other loading conditions, such as a driveway above the wall, require special consideration. These should be built as reinforced walls using other construction techniques, including the use of geogrid. A civil/soils engineer and a professional contractor should be used for these situations.

Ideal Block's retaining walls, pillars, and free-standing walls require different construction methods. Please see our wall guides available at www.IdealBlock.com for more information on installation.

Play it safe and contact your Ideal Block Authorized Dealer for more information regarding the above special considerations.